



# ASSEMBLY INSTRUCTION FOR FESP134-6688-DT-W

<b>Note</b> • Read instructions carefully • Carefully identify each component especially those that are similar. • Separate and identify each component from the hardware pack and rest each one in its proper location before fastening. • Do not over tighten the screws or bolts when assembling.	 <b>2 Persons</b>	<b>TOOL REQUIRED</b> 
--	--	---

**STEP 1**

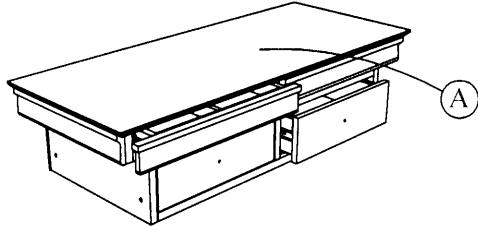

Firstly take out the hidden drawer and drawer as shown.

**STEP 2**

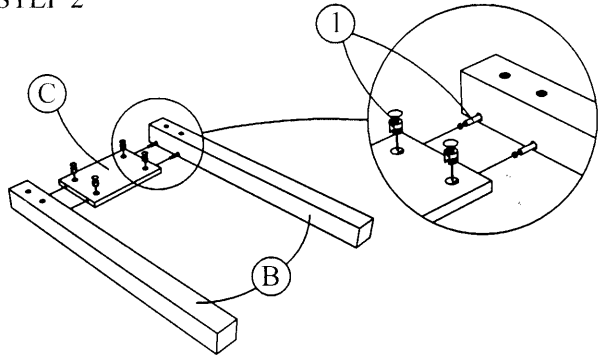

Fix leg L/R 'B' to the side panel-A 'C' with mini fix '1' as shown.

**STEP 3**

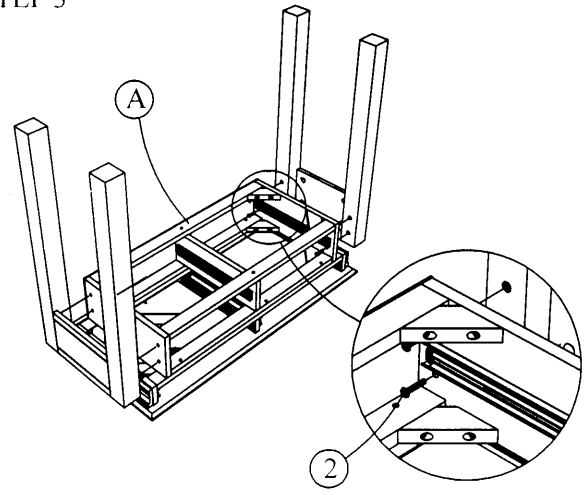

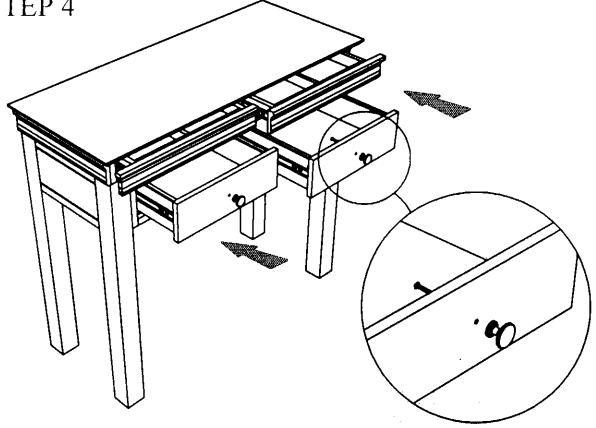

Fix the side legs L/R to the dresser box 'A' with bolt's '2' as shown.

**STEP 4**

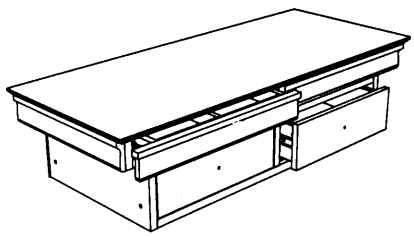
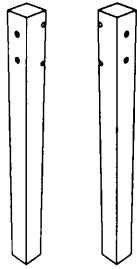
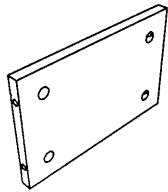
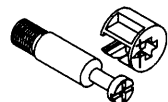

Fix handle to the drawer with screws handle. At last put back the drawer and hidden drawer into the drawer box and make sure all bolts and screws are tighten.

NO	PART	QTY
A	 DRESSER BOX	1 PC
B	 LEG L/R	4 PCS
C	 SIDE PANEL-A	2 PCS
NO	HARDWARE	QTY
1	 MINI FIX	8 PCS
2	 JCBC BOLT M6 x 30mm	8 PCS
3	 M6- Allen key	1 PC



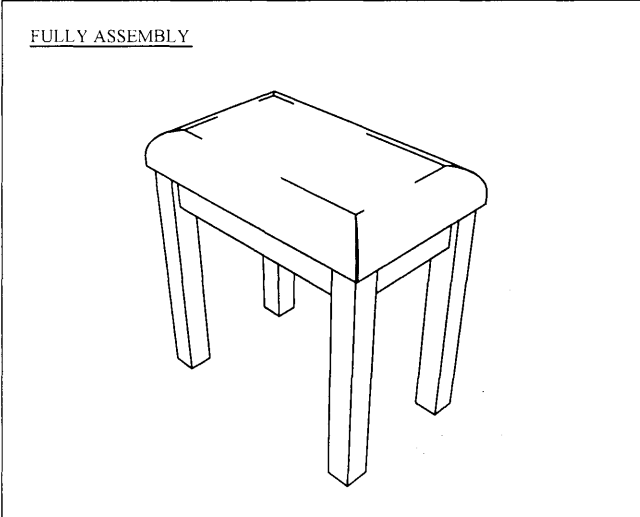
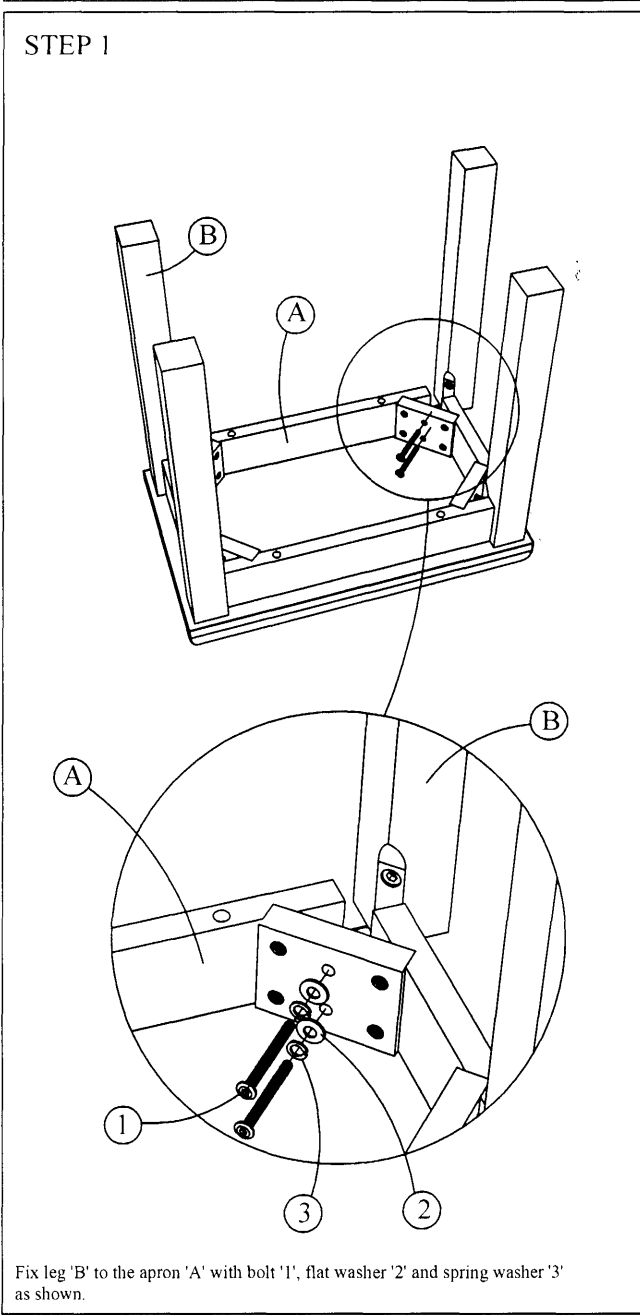
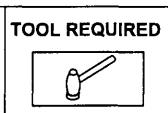

**Please follow our assembly instruction procedure for easier assemble.**

# ASSEMBLY INSTRUCTION FOR 6688-STOOL

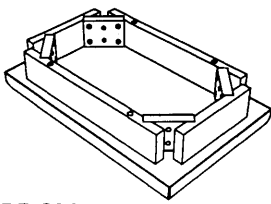
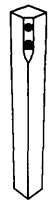
Note:  
 • Read instructions carefully.  
 • Carefully identify each component especially those that are similar.  
 • Separate and identify each component from the hardware pack and fast each one in its proper location before fastening.  
 • Do not over tighten the screws or bolts when assembling.



NO	PART	QTY
A	 APRON	1 PC
B	 LEG	4 PCS

NO	HARDWARE	QTY
1	 JCBC BOLT M6 x 60mm	8 PCS
2	 WASHER M6	8 PCS
3	 SPRING WASHER M6	8 PCS
4	 M6- ALLEN KEY	1 PC

Please follow our assembly instruction procedure for easier assemble.